

INSPECTION

Using Scan Tool

<Volume Air Flow Sensor>

Function	Item No.	Data display	Check condition	Engine state	Standard value
Data reading	12	Sensor air volume (frequency)	<ul style="list-style-type: none"> • Engine coolant temperature: 80 to 95°C (176 to 203°F) • Lights and accessories: OFF • Transaxle: Neutral (P range for vehicle with A/T) • Steering wheel: Neutral 	700 rpm (Idle)	22-48 Hz
				2,000 rpm	50-90 <Non turbo> 68-108 <Turbo>
				Racing	Frequency increases with racing

NOTE
When the vehicle is new [within initial operation of about 500 km (300 miles)], the volume air flow sensor output frequency may be about 10% higher.

<Volume Air Flow Sensor Reset Signal>

Function	Item No.	Data display	Check conditions	Engine conditions	Standard value
Data list	34	Reset signal condition	<ul style="list-style-type: none"> • Engine warm up 	700 rpm (Idle)	ON
				2,000 rpm	OFF

<Volumetric Efficiency>

Function	Item No.	Data display	Check condition	Engine state	Standard value
Data list	37	Volumetric efficiency	<ul style="list-style-type: none"> • Engine coolant temperature: 80 to 95°C (176 to 203°F) • Lights, electric cooling fan and accessory operation: OFF • Transaxle: Neutral (P range for vehicle with A/T) • Steering wheel: Neutral 	700 rpm (Idle)	15-35 %
				2,000 rpm	15-35 %
				Racing	Frequency increases with racing

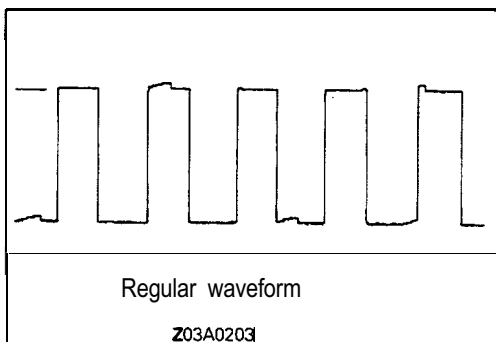

Using Oscilloscope

- (1) Run the engine at idle speed.
- (2) Connect the probe to the oscilloscope pick-up point as shown in the circuit diagram, and check the waveform.

HARNESS INSPECTION

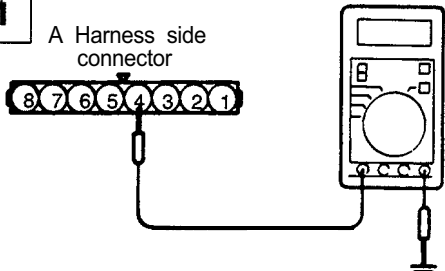
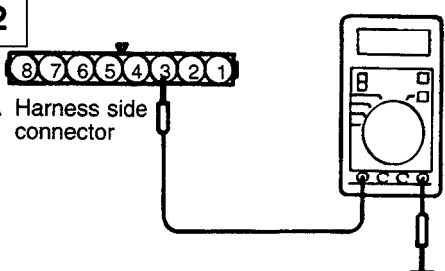
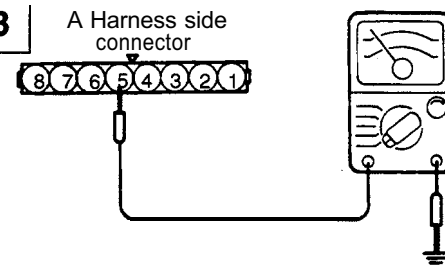
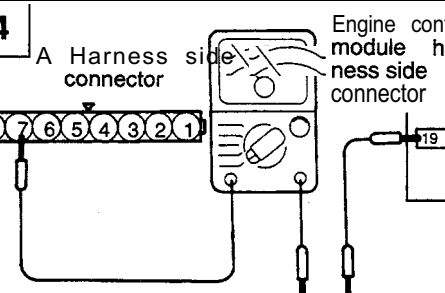
<p>1</p> <p>A Harness side connector</p>  <p>Z7FU0655</p>	<p>Measure the power supply voltage.</p> <ul style="list-style-type: none"> • Connector: Disconnected • Ignition switch: ON <p>Battery voltage</p>	<p>OK → 2</p> <p>✗ → Repair the harness (A4 – Control relay) or check the control relay.</p>
<p>2</p> <p>A Harness side connector</p>  <p>Z7FU0656</p>	<p>Measure the terminal voltage.</p> <ul style="list-style-type: none"> • Connector: Disconnected • Ignition switch: ON <p>4.8–5.2 V</p>	<p>OK → 3</p> <p>✗ → Repair the harness. (A3–70)</p>
<p>3</p> <p>A Harness side connector</p>  <p>Z7FU0657</p>	<p>Check for continuity of the ground circuit.</p> <ul style="list-style-type: none"> • Connector: Disconnected 	<p>OK → STOP</p> <p>✗ → Repair the harness. (A5–72)</p>
<p>4</p> <p>A Harness side connector</p> <p>Engine control module harness side connector</p>  <p>Z7FU0745</p>	<p>Check for continuity between the volume air flow sensor and the engine control unit.</p> <ul style="list-style-type: none"> • Volume air flow sensor connector: Disconnected • Engine control module connector: Disconnected 	<p>OK → STOP</p> <p>✗ → Repair the harness. (A7–19)</p>

INTAKE AIR TEMPERATURE SENSOR

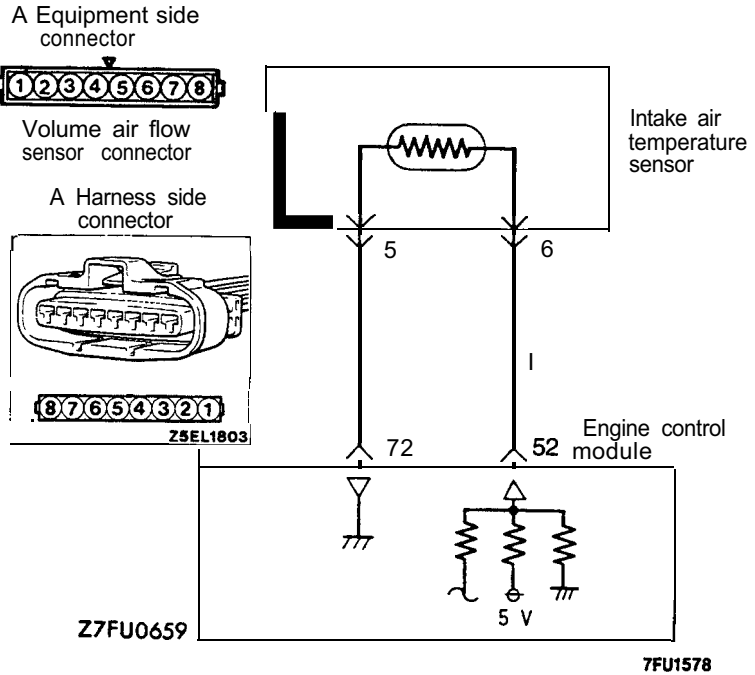
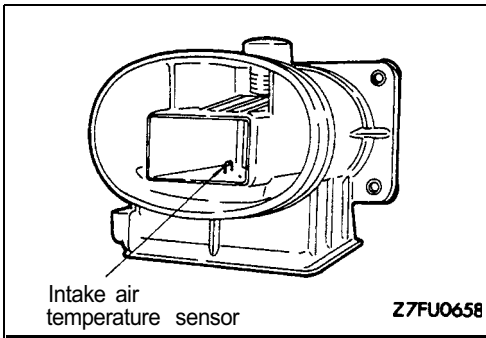
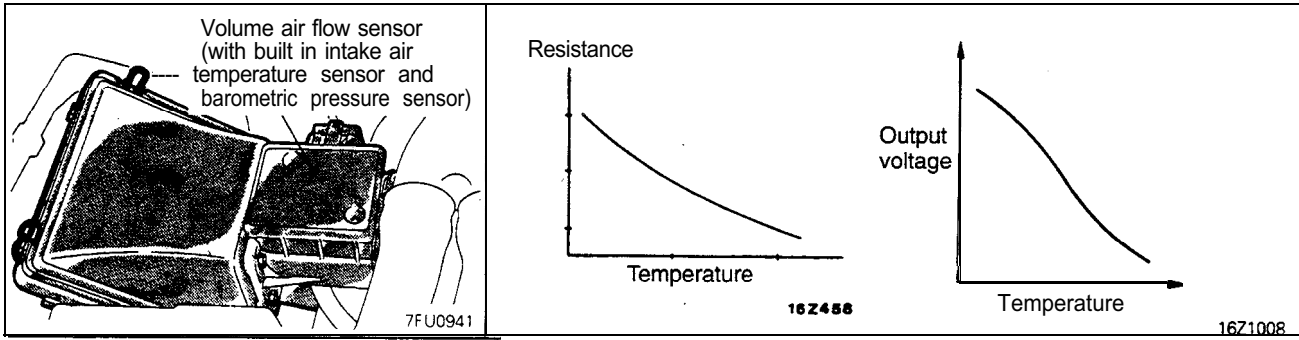

OPERATION

- The intake air temperature sensor converts the engine intake air temperature into a voltage and inputs it to the engine control module, which then corrects the fuel injection rate, etc. based on the input signal.
- The 5 V power in the engine control module is supplied via a resistor in the module to the intake air temperature sensor. Via the sensor which is a kind of resistor, it is grounded in the engine control module. The intake air temperature sensor resistor has the characteristic of decreasing its resistance as the intake air temperature rises.
- The intake air temperature sensor terminal voltage increases or decreases as the sensor resistance increases or decreases. Therefore, the intake air temperature sensor terminal voltage changes with the intake air temperature, decreasing as the temperature rises.

TROUBLESHOOTING HINTS

The intake air temperature sensor senses the intake air temperature in the air cleaner so that it may indicate a temperature different from outside temperature depending on engine operating state.

INSPECTION

Using Scan Tool

Function	Item No.	Data display	Check condition	Intake air temperature	Standard value
Data reading	13	Sensor temperature	Ignition switch: ON or engine running	At -20°C (-4°F)	-20°C
				At 0°C (32°F)	0°C
				At 20°C (68°F)	20°C
				At 40°C (104°F)	40°C
				At 80°C (176°F)	80°C

HARNES INSPECTION

1 A Harness side connector

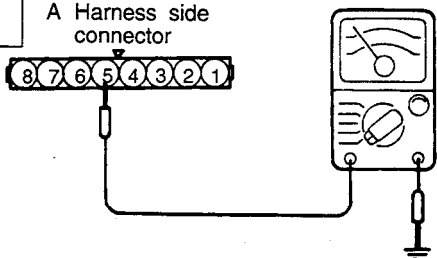

Z7FU0657

Check for continuity of the ground circuit.

- Connector: Disconnected

OK → **2**

✗ → Repair the harness. (A5-72)

2 A Harness side connector

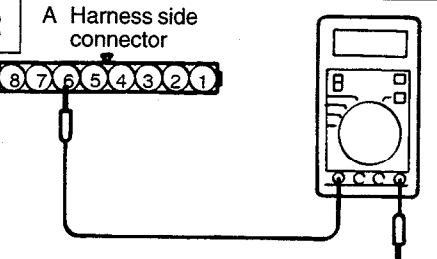

Z7FU0660

Measure the power supply voltage.

- Ignition switch: ON
- Connector: Disconnected

4.5-4.9 V

OK → STOP

✗ → Repair the harness. (A6-52)

Volume air flow sensor side connector

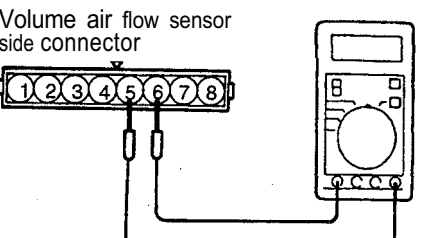

Z7FU0661

SENSOR INSPECTION

- Disconnect the volume air flow sensor connectors.
- Measure resistance between terminals (5) and (6).

Temperature [°C(°F)]	Resistance (kΩ)
0 (32)	6.0
20 (68)	2.7
80 (176)	0.4

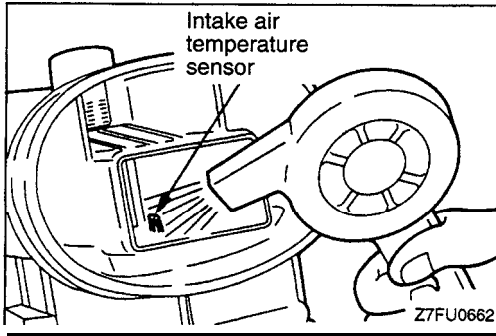

- (3) Measure resistance while heating the sensor using a hair drier.

Temperature [°C (°F)]	Resistance (kΩ)
Higher	Smaller

- (4) If resistance does not decrease as heat increases or the resistance remains unchanged, replace the volume air flow sensor assembly.

BAROMETRIC PRESSURE SENSOR

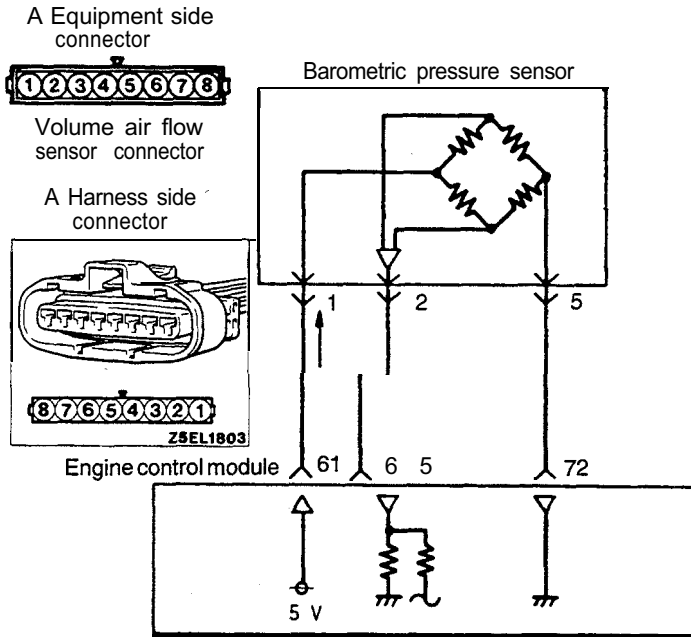
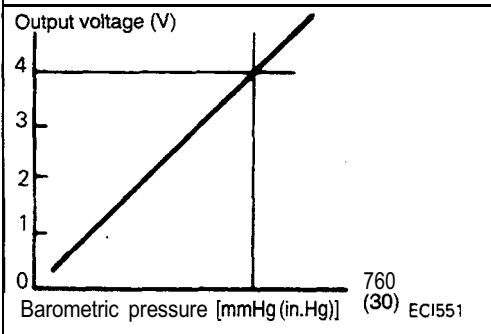
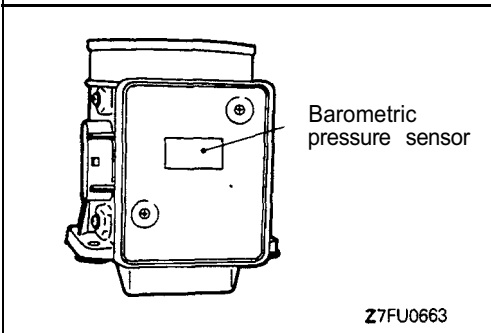
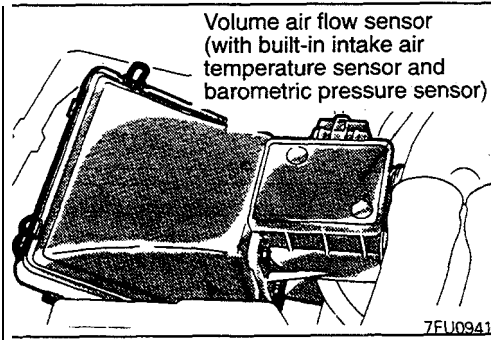

Engine control unit connector

1	2	3	4	5	6	7	8	9	10	11	12	13	14	15	16	17	18	19	20	21	22	23	24	25	26	27	28	29	30	31	32	33	34	35	36	37	38	39	40	41	42	43	44	45	46	47	48	49	50	51	52	53	54	55	56	57	58	59	60	61	62	63	64	65	66	67	68	69	70	71	72	73	74	75	76	77	78	79	80	81	82	83	84	85	86	87	88	89	90	91	92	93	94	95	96	97	98	99	100
---	---	---	---	---	---	---	---	---	----	----	----	----	----	----	----	----	----	----	----	----	----	----	----	----	----	----	----	----	----	----	----	----	----	----	----	----	----	----	----	----	----	----	----	----	----	----	----	----	----	----	----	----	----	----	----	----	----	----	----	----	----	----	----	----	----	----	----	----	----	----	----	----	----	----	----	----	----	----	----	----	----	----	----	----	----	----	----	----	----	----	----	----	----	----	----	----	----	----	-----

Z7FU0653

7FU1579

OPERATION

- The barometric pressure sensor converts the barometric pressure into a voltage and inputs it to the engine control module, which then corrects the fuel injection, rate, etc. based on the input signal.
- The 5 V power in the engine control module is supplied to the barometric pressure sensor. Through the circuit in the sensor, it is grounded in the engine control module.
- The barometric pressure sensor output voltage which is proportional to the barometric pressure (absolute pressure) is supplied to the engine control module.

TROUBLESHOOTING HINTS

Hint 1: If the barometric pressure sensor is faulty, poor driveability is caused at high altitude, in particular.
 Hint 2: If the pressure indication of the barometric pressure sensor drops significantly during high speed driving, check the air cleaner for clogging.

INSPECTION

Using Scan Tool

Function	Item No.	Data display	Check condition	Altitude	Standard value
Data reading 25		Sensor pressure	Ignition switch: ON	At 0 m (0 ft.)	101 kPa (760 mmHg)
				At 600 m (1,969 ft.)	95 kPa (710 mmHg)
				At 1,200 m (3,937 ft.)	88 kPa (660 mmHg)
				At 1,800 m (5,906 ft.)	81 kPa (610 mmHg)

HARNES INSPECTION

<p>1 A Harness side connector</p> <p>Z7FU0657</p>	<p>Check for continuity of the ground circuit.</p> <ul style="list-style-type: none"> Connector: Disconnected <p>OK → 2</p> <p>✗ → Repair the harness. (A5-72)</p>
<p>2 A Harness side connector</p> <p>Z7FU0665</p>	<p>Measure the power supply voltage of the barometric pressure sensor.</p> <ul style="list-style-type: none"> Connector: Disconnected Ignition switch: ON <p>4.8-5.2 V</p> <p>OK → 3</p> <p>✗ → Repair the harness. (A1-61)</p>
<p>3 A Harness side connector</p> <p>Z7FU0666</p>	<p>Check for an open-circuit, or a short-circuit to ground between the engine control module and the barometric pressure sensor.</p> <ul style="list-style-type: none"> Volume air flow sensor connector: Disconnected Engine control module connector: Disconnected <p>OK → STOP</p> <p>✗ → Repair the harness. (A2-65)</p>